



# CX-B 系列 透浦式鼓風機 TURBO BLOWER



IE3 CE UL



## CX-B特色 CX-B Features

轉速快、用電省、風量大、噪音低  
 搭配IE3高效率馬達(1HP以上)  
 鋁合金製造，結構強，重量輕  
 心軸油封設計，防止液體及粉塵進入馬達

Fast rotation, energy saving, large air volume, and low noise.  
 With IE3 high efficiency motor (above 1HP).  
 With aluminum materials, strong structure and light weight.  
 Core shaft with oil seal , prevents liquid and dust from entering motor.

## 用途 Applications

製藥機械、食品機械、木工機械、薄膜機械、乾燥機、  
 粉粒體輸送、包裝機械、印刷機械、紡織機械、  
 散熱，送風，集塵，負壓吸引、及其他送風用途

Pharmaceutical machines , Food Processing machines,  
 Woodworking machines, Film extrusion machines, dryers,  
 Powders and granules transport , Packaging machines,  
 Printing machines, Textile machines, Heat dissipation, Air  
 supply, Dust collection, Negative pressure attraction, and  
 other air supply purposes.

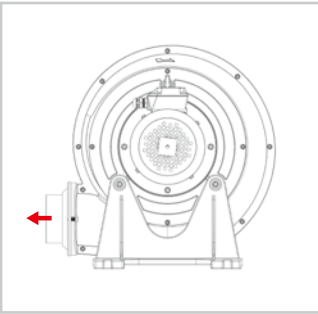
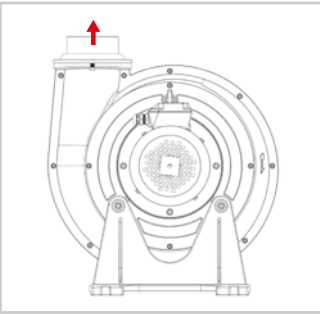
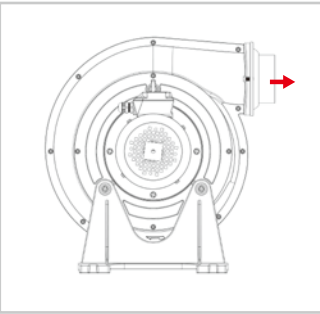
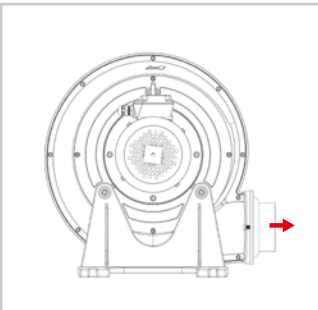
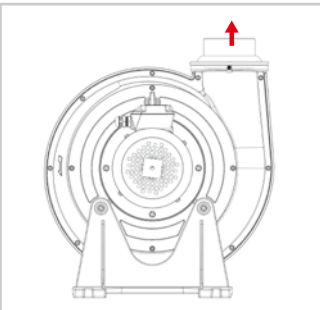
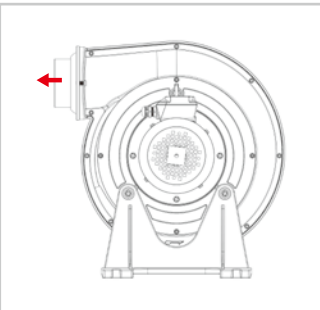
出口方向 Blower set 馬達方向 Motor set	Bottom	Up	Top
	1	2	3
R			
L			

CX-B 系列標準出廠方向 0.5HP~5HP L1 方向  
 7.5HP~20HP R1 方向

出口方向也可以根據客戶需求而轉向。  
 拆卸方式請參考下圖或操作手冊。

Our standard model (0.5HP-5HP) is as L1, (7.5HP-20HP) is as R1.  
 The outlet direction of all blowers can be changed as showed  
 on the chart.

More information about the outlet direction changing operation,  
 Please refer to the chart or instruction manual.

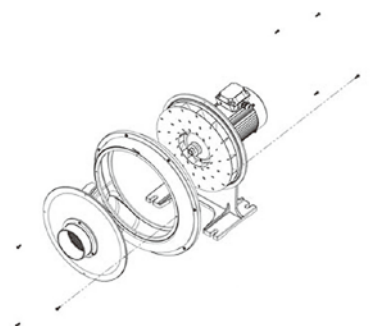

## 應用圖例－送風用 Application Graphic - For Air Supply

### 印刷紙乾燥 Drying of printing paper

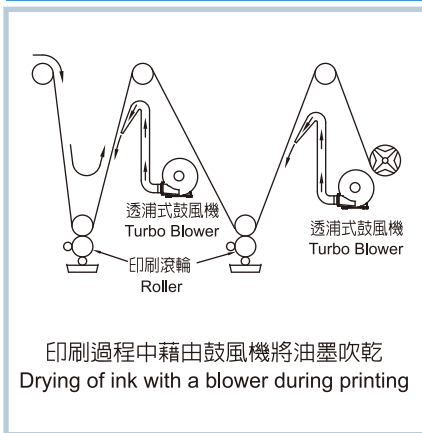

### 洗碗機器 Dishwasher

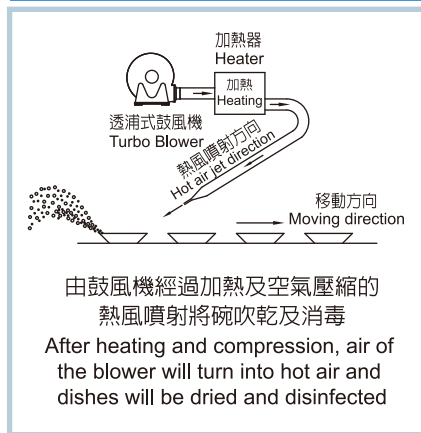

### 粉粒體輸送 Powders and granules transport

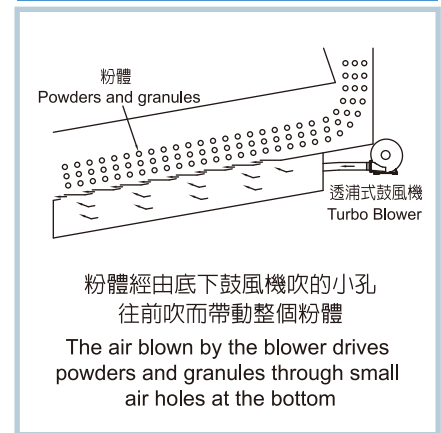

### 送料機 Feeder

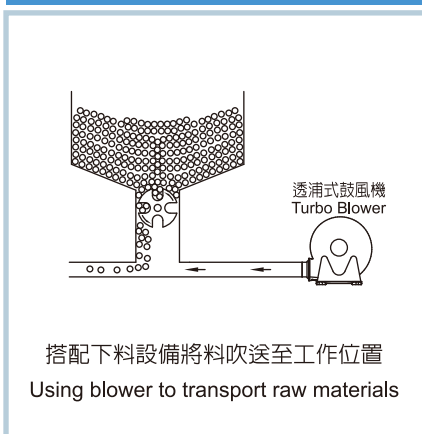

### 散熱 Heat dissipation

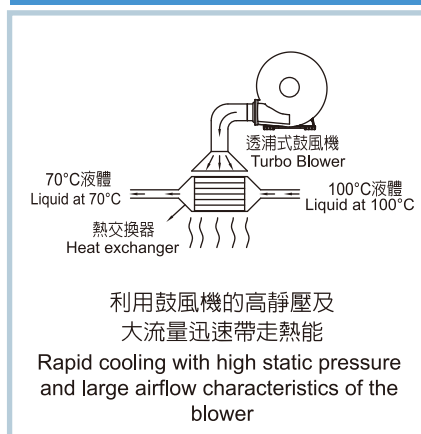

### 超音波清洗 Ultrasonic cleaning machine

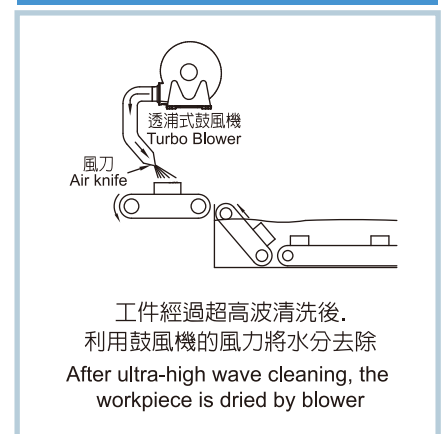

### 熱風排氣設備 Hot air exhaust equipment

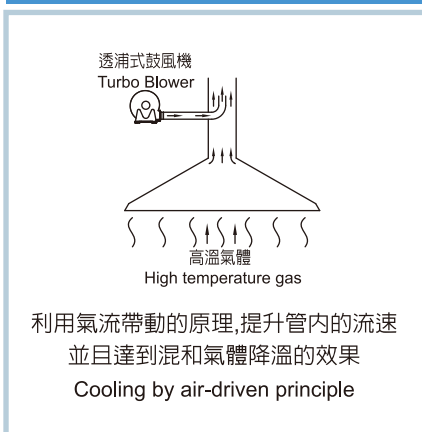

### 薄膜機 Film extrusion machine

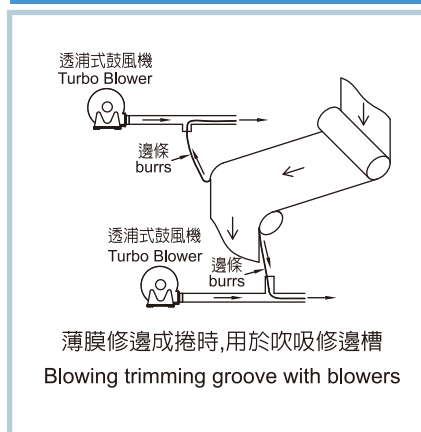

### 熱風產生機 Hot air generator

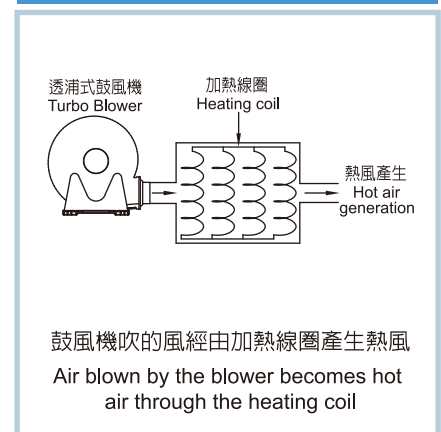

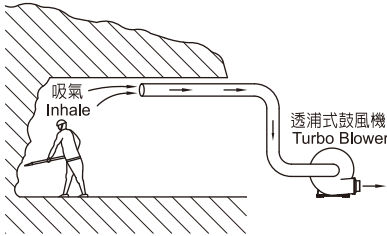
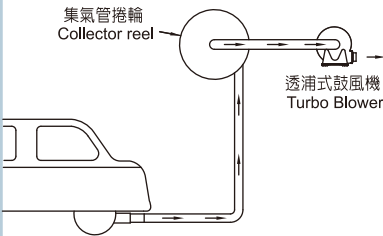
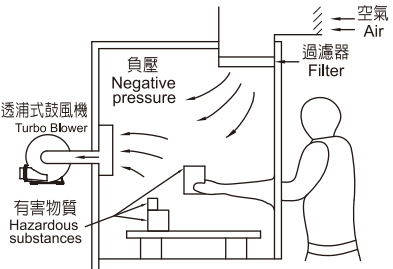
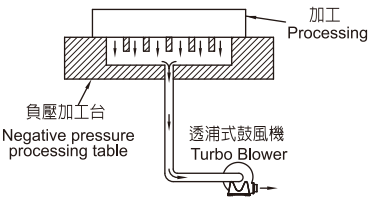
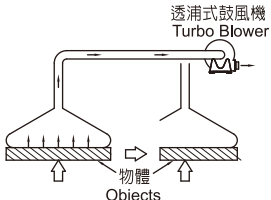
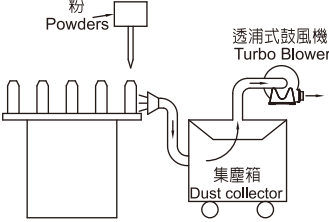
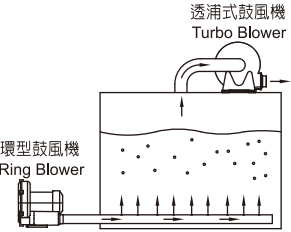
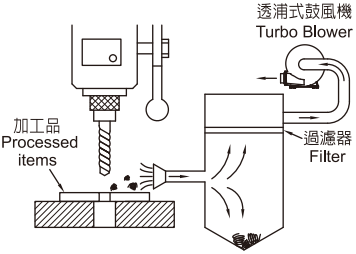
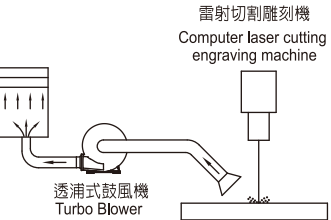

## 應用圖例－吸風用 Application Graphic - For Air Suction

<p><b>工程現場</b> Project site</p>  <p>吸氣 Inhale 透浦式鼓風機 Turbo Blower</p> <p>工程現場隧道內部吸取不良空氣 Take the exhaust gas out of the tunnel</p>	<p><b>汽車工作場所</b> Automobile workplace</p>  <p>集氣管捲輪 Collector reel 透浦式鼓風機 Turbo Blower</p> <p>汽車工作場所排氣 Discharge the exhaust from automobile workplace</p>	<p><b>負壓作業空間</b> Negative pressure workplace</p>  <p>透浦式鼓風機 Turbo Blower 負壓 Negative pressure 過濾器 Filter Air 有害物質 Hazardous substances</p> <p>物品製造過程中,需要隔離有害物質 Emission of harmful gases generated during production</p>
<p><b>真空吸附</b> Vacuum suction</p>  <p>加工 Processing 負壓加工台 Negative pressure processing table 透浦式鼓風機 Turbo Blower</p> <p>木板或磁力不能吸附的物品使用真空吸取 Use vacuum to suck away objects that cannot be absorbed by wood or magnetism</p>	<p><b>真空搬運</b> Vacuum handling</p>  <p>透浦式鼓風機 Turbo Blower 物體 Objects</p> <p>真空吸盤搬運可使作業更省力 Handling with vacuum sucker makes operation more labor-saving</p>	<p><b>粉體充填</b> Powders particle filling</p>  <p>粉 Powders 透浦式鼓風機 Turbo Blower 集塵箱 Dust collector</p> <p>作業現場的粉塵收集 Dust collection</p>
<p><b>發酵槽</b> Fermentation tank</p>  <p>透浦式鼓風機 Turbo Blower 環型鼓風機 Ring Blower</p> <p>肥料發酵使用,下方使用環形風機吹氣,上方使用透浦風機吸取發酵氣體 Fertilizer fermentation: using a ring blower to blow at the bottom, using a turbo blower to suck up fermented gas from above</p>	<p><b>碎屑吸取</b> Debris suction</p>  <p>透浦式鼓風機 Turbo Blower 加工品 Processed items 過濾器 Filter</p> <p>加工時產生的碎屑及粉塵吸取 Absorb debris and dust from processing</p>	<p><b>電腦雷射切割雕刻機</b> Computer laser cutting engraving machine</p>  <p>雷射切割雕刻機 Computer laser cutting engraving machine 透浦式鼓風機 Turbo Blower</p> <p>雷射雕刻作業時產生的粉塵吸取 Dust absorption</p>

### CX-B04

0.4kW

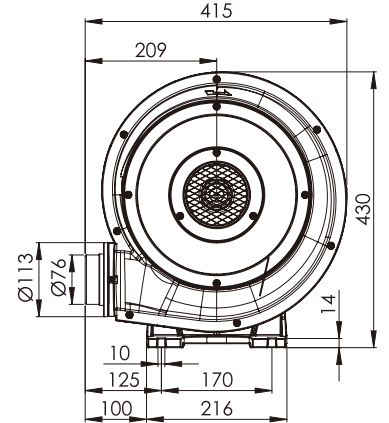
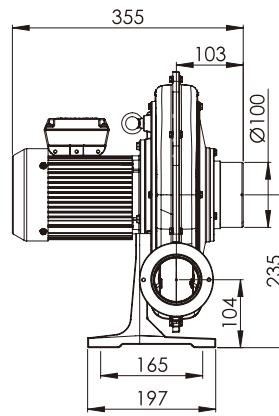
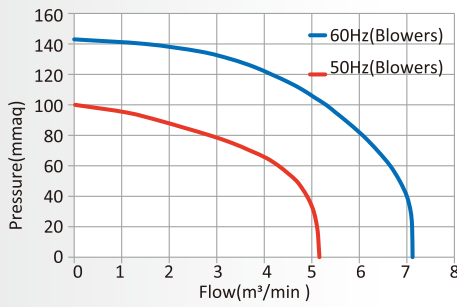

### CX-B04A

0.4kW

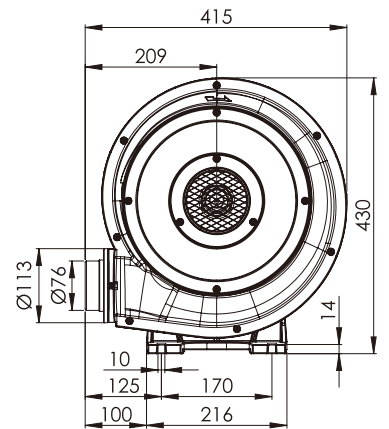
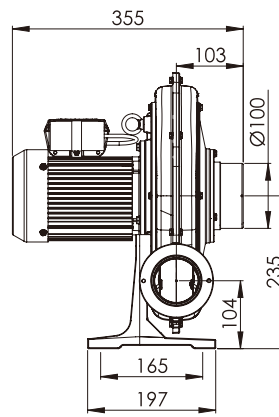
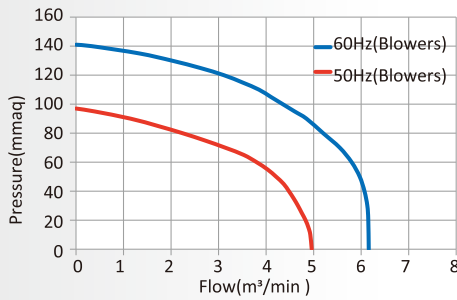

### CX-B07

0.75kW

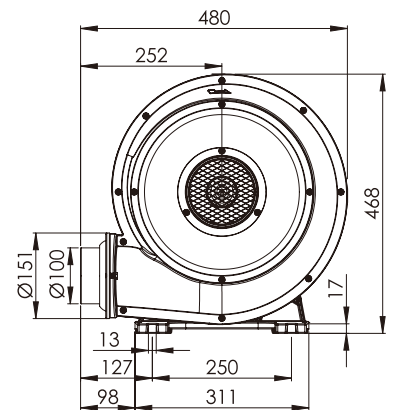
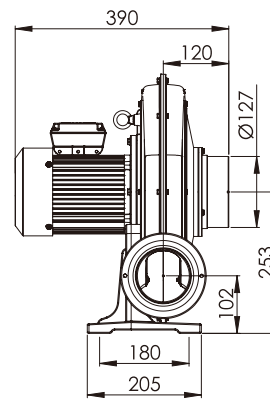
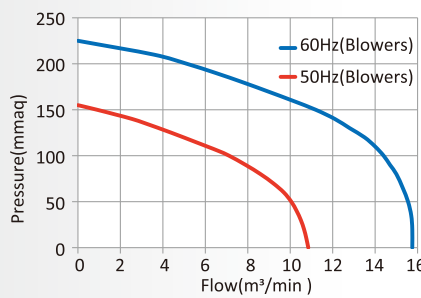

### CX-B07A

0.75kW

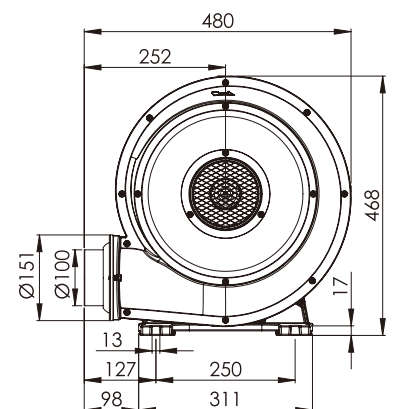
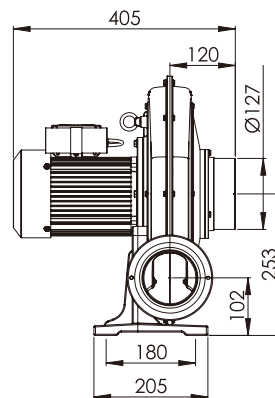
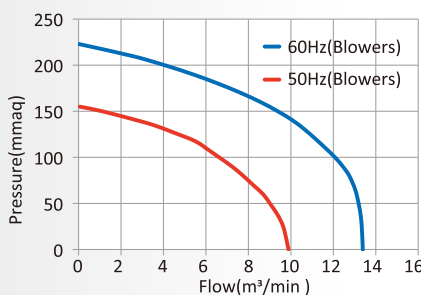



## CX-B15

1.5kW

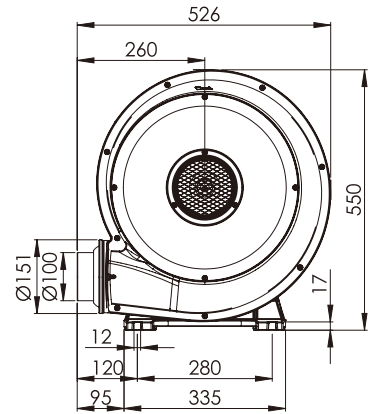
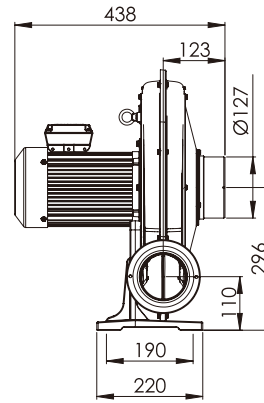
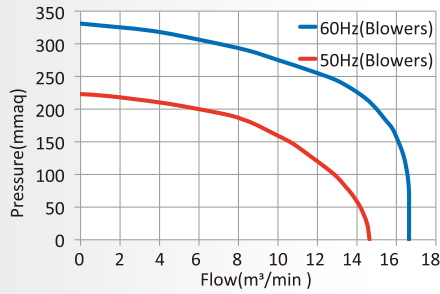

## CX-B15A

1.5kW

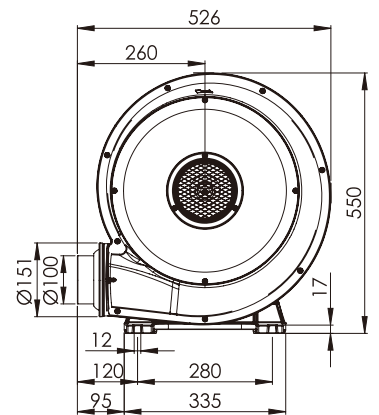
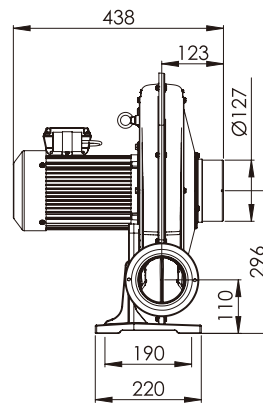
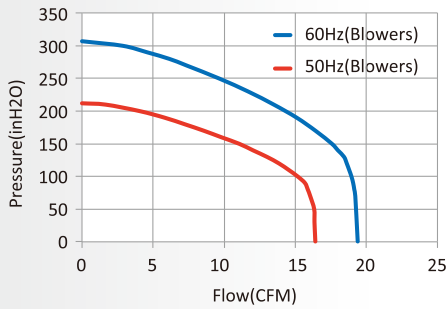

## CX-B22

2.2kW

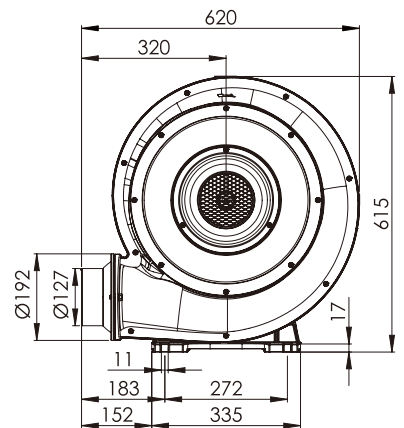
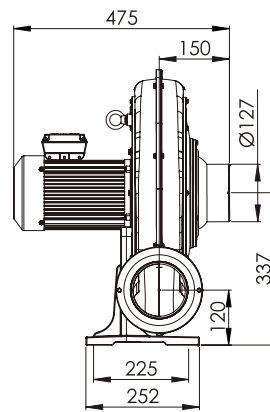
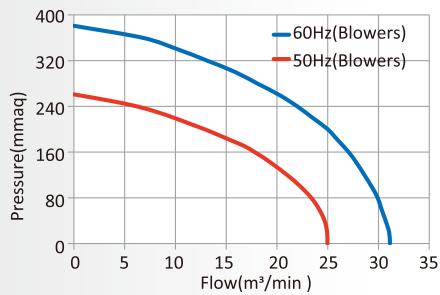

## CX-B37

3.7kW

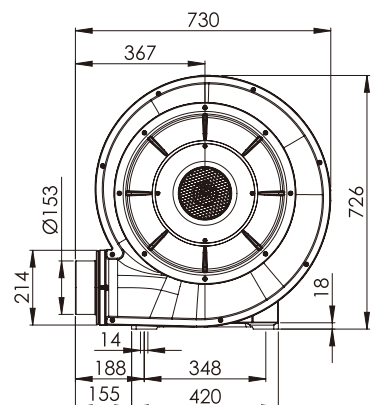
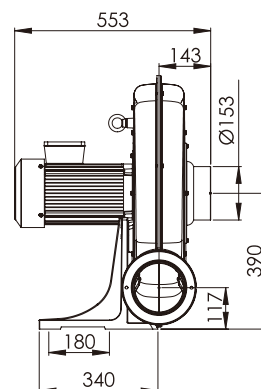
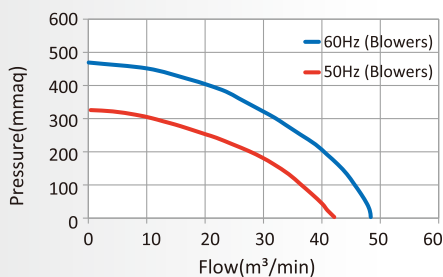

### CX-B55

5.5kW

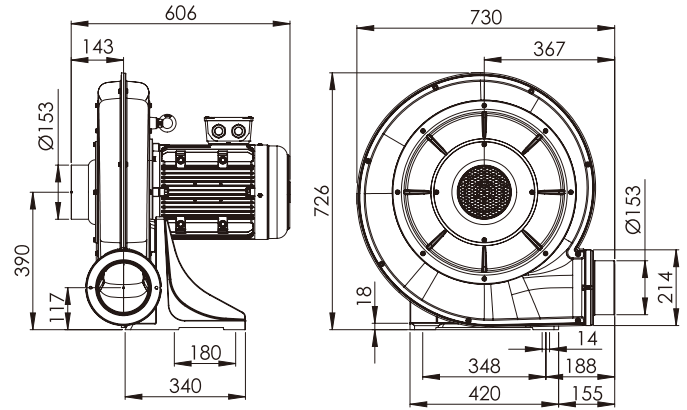
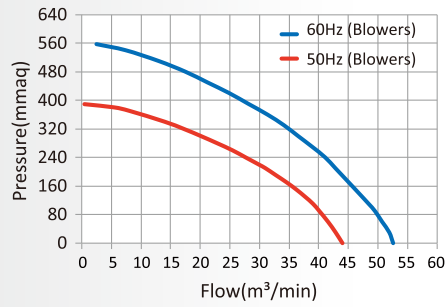

### CX-B75

7.5kW

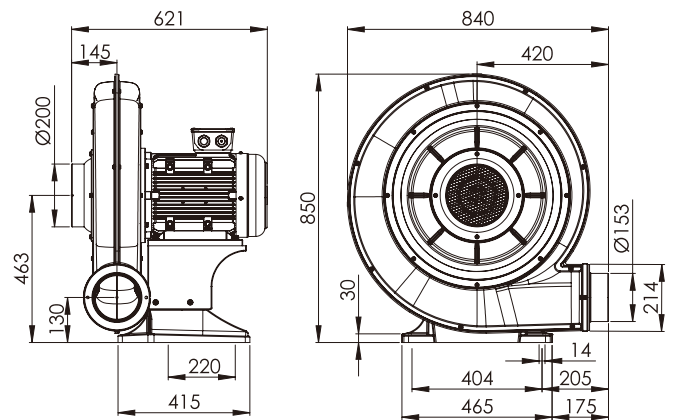
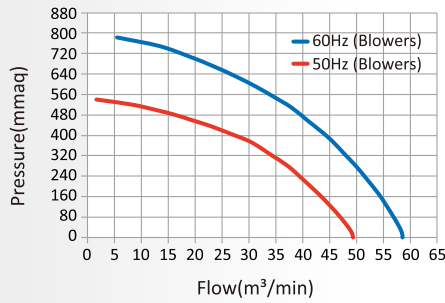

### CX-B110

11kW

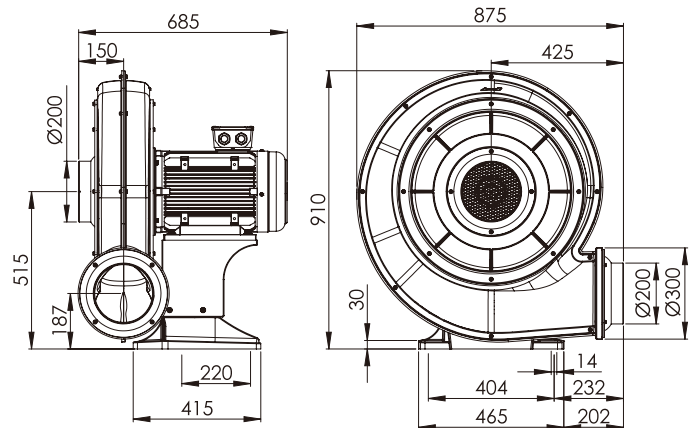
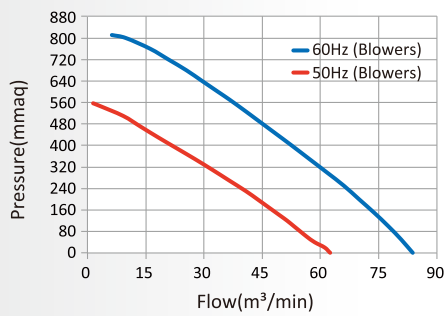

### CX-B150

15kW

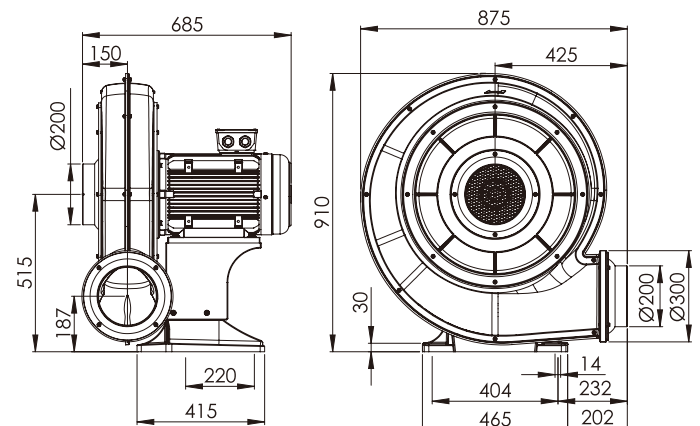
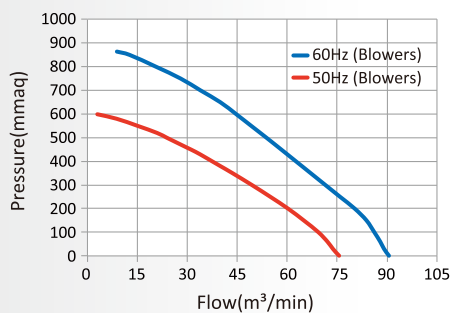

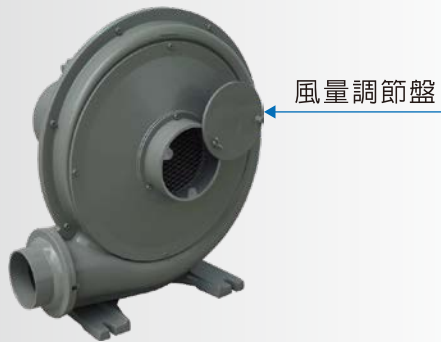

送風使用時，可搭配調節盤，依客戶需求而使用，可以調節入風口風量大小。

Air Regulating disc is often used by customers to control volume of the inlet.

### 三相 (Three Phase )

型號 TYPE	功率 Power	頻率 Frequency	電壓 Voltage	額定電流 Rated Current	轉速 Speed	最大吐出壓力 Pressure(Max.)		最大吐出風量 Air Flow( Max.)		噪音 Noise Level	重量 Approx. Weight
						mmAq	Kpa	m³/min	CFM		
CX-B04	0.4	50	220V/380V	1.7/0.98	2800	110	1.08	7	247	75.2	15
		60		1.9/1.1	3500	155	1.52	8	283	77.6	
CX-B07	0.75	50		3.0/1.74	2800	150	1.47	12	424	85.4	20
		60		3.2/1.85	3500	210	2.06	15	530	86.7	
CX-B15	1.5	50		7.0/4.05	2800	215	2.11	16	565	87.8	28.5
		60		7.2/4.2	3500	315	3.09	19	671	93.2	
CX-B22	2.2	50		10.0/5.8	2800	250	2.45	27	954	92	37.5
		60		11.0/6.4	3500	365	3.58	32	1131	96	
CX-B37	3.7	50		13.0/7.5	2800	320	3.14	41	1449	97.2	62
		60		15.0/8.7	3500	460	4.51	47	1661	99	
CX-B55	5.5	50		19.0/11.0	2800	380	3.73	44	1555	101.1	94
		60		23.0/13.3	3500	550	5.39	52	1837	103.3	
CX-B75	7.5	50		27.0/15.6	2800	530	5.20	49	1731	101.2	114.5
		60		28.0/16.2	3500	770	7.55	58	2049	104.9	
CX-B110	11	50	35.0/20.3	2800	560	5.49	70	2473	98.8	144.5	
		60	42.0/24.3	3500	810	7.94	83	2933	100.2		
CX-B150	15	50	51.0/29.5	2800	590	5.78	75	2650	100.6	152	
		60	55.0/31.8	3500	860	8.43	90	3180	104.2		

### 單相 (Single Phase )

型號 TYPE	功率 Power	頻率 Frequency	電壓 Voltage	額定電流 Rated Current	轉速 Speed	最大吐出壓力 Pressure(Max.)		最大吐出風量 Air Flow( Max.)		噪音 Noise Level	重量 Approx. Weight
						mmAq	Kpa	m³/min	CFM		
CX-B04A	0.4	50	110V/220V	4.7/2.4	2800	110	1.08	6.5	230	75.2	14.5
		60		5.4/2.7	3500	160	1.57	7.5	265	77.6	
CX-B07A	0.75	50		10.0/5.0	2800	150	1.47	11.5	406	85.6	21
		60		11.0/5.5	3500	210	2.06	14	495	86.7	
CX-B15A	1.5	50	220V	10	2800	205	2.01	16	565	86.5	29
		60		10.5	3500	300	2.94	19	671	86.7	

由於技術上的需要，我們保留設計與尺寸變更的權利，特殊電壓可訂製



## 型號編碼原則

# C X - B 04 A

<b>CX</b>	透浦式鼓風機系列 Turbo Blower Series	無	舊型 Old Type	無	三相 Three Phase
	<b>LG</b>		高壓鼓風機系列 Ring Blower Series		<b>B</b>
			<b>E</b>	大風量 High Air Volume	
			<b>K</b>	高壓大風量 High Pressure and High Air Volume	
				<b>04</b>	0.4kW
				<b>07</b>	0.75kW
				<b>15</b>	1.5kW
				<b>22</b>	2.2kW
				<b>37</b>	3.7kW
				<b>55</b>	5.5kW
				<b>75</b>	7.5kW
				<b>110</b>	11kW
				<b>150</b>	15kW

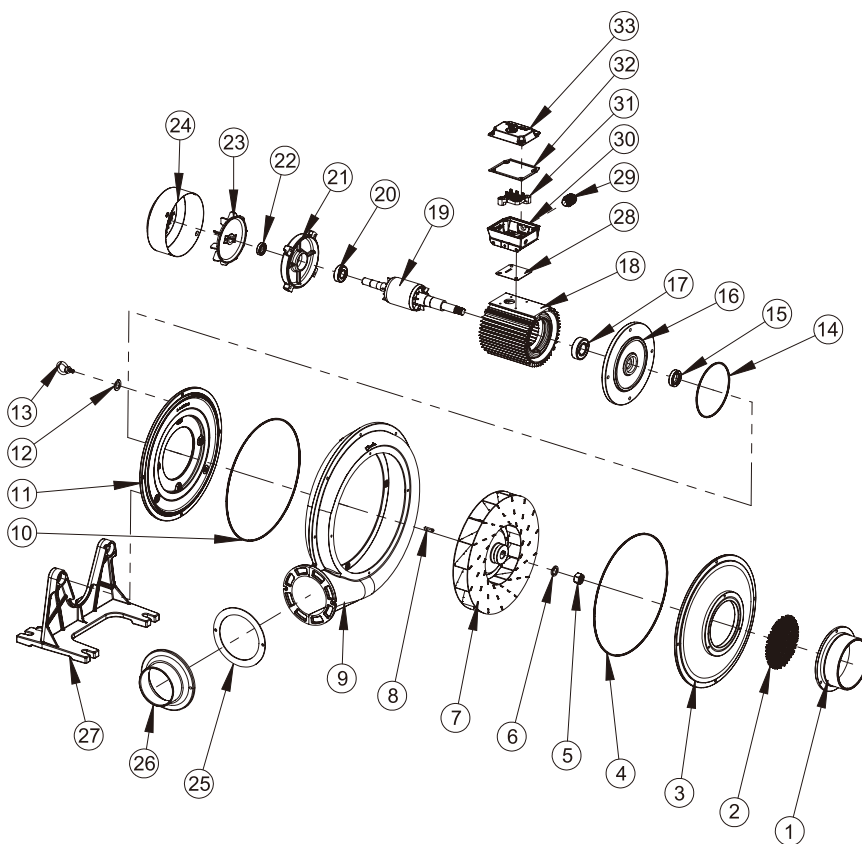

項次 Item	零件名稱 Parts Name	數量
1	入風口 Inlet flange	1
2	菱形網 Net	1
3	鼓風機機蓋 Front cover	1
4	O型環 O-ring	1
5	螺帽 Nuts	1
6	彈簧華司 Spring washer	1
7	葉片 Impeller	1
8	定位銷 Pin	1
9	鼓風機機殼 Casing	1
10	O型環 O-ring	1
11	馬達座蓋 Casing cover-rear	1
12	彈簧華司 Spring washer	1
13	吊環 Hook ring	1
14	O型環 O-ring	1
15	前油封 Oil seal-front	1
16	馬達座 Motor shield	1
17	前軸承 D side bearing	1
18	馬達 Motor	1
19	轉子 Rotor & shaft assembly	1
20	後軸承 Bearing-rear	1
21	馬達後蓋 Rear housing	1
22	後油封 Oil seal-rear	1
23	散熱葉片 Fan	1
24	風蓋 Fan cover	1
25	出風口墊片 Delivery outlet spacer	1
26	出風口 Delivery outlet	1
27	腳座 Foot	1
28	墊片 Spacer	1
29	電纜固定頭 Cable head	1
30	接線盒座 Terminal box	1
31	接線板 Terminal plate	1
32	墊片 Spacer	1
33	接線盒蓋 Terminal box cover	1

## 透浦式鼓風機之特性與使用 The Features and Installation of Turbo Blower

### 使用要點 Important Points For Operating

透浦式鼓風機運轉時，其壓力與電流成反比，如電流過大會導致接觸器跳脫，為防止跳脫或省電，當管路很短或阻力很少時，請使用風量調節盤。進出氣口之總截面積應在鼓風機進出口截面積之70%以下。

送風用-通常有附上風量調節盤。

When the turbo type blower is in operation, its pressure has an inverse ratio to the current. If the current is too high, the contactor will trip. In order to avoid tripping or for saving power, when the pipe is very short, or the resistance is very less, please use wind regulating disc. The total section area of the air hole should be less than 70% of the section area of the blower mouth.

For feeding air – Wind regulating disc is included under normal situation.

### 檢查 Inspection

收到送風機時，請檢查以下各項

1. 標籤上所記載之事項，確實符合訂購事項 (如：電壓V、週率Hz、功率kW)。
2. 運送途中有無破損情形。

When you receive the blower, please check following items –

1. Do the contents on the label conform to what you order – for example, voltage, hertz and power (kW).
2. Are there any damages during the transportation.

### 安裝 Installation

A. 安裝場所 周圍溫度與濕度，應符合以下條件：

- 單相-5~40°C ● 三相-10~40°C
- 選擇通風良好，塵埃及濕氣少之場所。
- 安裝於露天者，請使用雨罩。

B. 安裝方法 1. LONG-GOOD高壓鼓風機以水平方向安裝，用螺絲確實固定於水平且具剛硬的基礎或基座上。基礎重量大約是鼓風機的3倍以上為標準。應特別注意基座是否高低不平，如果是，當螺栓扭緊時，鼓風機台可能發生變形!應加裝避震器降低噪音。 2. 鼓風機通常是軸承水平狀態設計，吸入口在向上或向下之情形使用時，翼輪及轉子之重量均加在一側的軸承上，使其荷重增加，軸承壽命因而降低。縱型安裝之鼓風機使用者，請先洽詢本公司。

(1) Installation Site Ambient Temperature and humidity should meet the following conditions:

- Single phase - 5 ~ 40°C ● There phase - 10 - 40°C
- Select site with good ventilation and less dust and humidity.
- Please use umbrella when installation is made on an open space.

(2) Methods of Installation: 1. Secure the installation with screw on leveling and hard foundation or base. Standard basic weight is generally about 3 times of blower. If the base is uneven, the blower stand may be deformed during fixing of screw. It is therefore that special attention should be made to install additional vibration control unit to reduce its noise. 2. Blower is normally designed to make bearing on axial leveling position. When suction inlet is upward or downward during application, the weight of impeller and rotor shaft are added on one side bearing to enlarge over load and thus reducing life of bearing. Please contact our business department first when vertical site is used.

### 配線 Wiring

1. 電源請使用定格電壓之定格周波數 (標籤上之記載值)，且按配線圖裝配正確之線路。
2. 電壓之變動應於定格電壓的±5%之內。(10%亦可使用，但是長時間電壓變動太大時，易造成故障，最好能避免。)
3. 由於鼓風機無熱過負載保護裝置，無法經常監控鼓風機之熱度，故請安裝相同馬力之過負載保護電磁開關。並調整與銘板值相同以下之安全電流。
4. 依據馬達之馬力及電氣工事方式，選擇標準的配線。歐盟可參考的安全資訊為：EN60034.EN60204-1.EN292.EN294.IEE配線法規。特定的工業及國家有進一步的安全要求，請諮詢他們的貿易及安規單位。
5. 確認迴轉方向：配線完成後，將開關開一下 (瞬間) 以確認其迴轉方向及有無雜音。迴轉方向如鼓風機上箭頭表示。如迴轉方向不對，為三相者，將三條電線中任意二條調換。
6. 接地為防止漏電時發生事故，請裝設地線。E(EARTH)。

1. The system rated voltage and frequency The record value same as those indicated on the rating plate.
2. Voltage variance should be kept within +5% of a rated voltage, +10% is sometime used, but it is better not to use as its voltage is too big and is liable to be broken down.
3. Due to blower has no over load heat protection fixture, it is unable to control heat. Therefore, please install overload protective magnetic switch of same horsepower and safe current is adjusted below same value of nameplate.
4. Select enough thickness of electric wire according to horse power of motor and electric working methods in accordance with European Union Safety information can be obtained from such as: EN60204-1 ; EN60034 ; EN292 ; EN294 ; IEE Wiring regulations Particular industries and countries have further safety requirements. Refer to their trade & safety bodies.
5. Check direction of rotation Turn on the switch for a while (twinkling) after completion of line connecting t check its rotation direction and noiseless. The arrow on blower indicates rotation direction. If rotation direction is wrong such as turning into 3 phase, just replace any 2 lines of 3 electric wires.
6. Grounding Please install earth lines to prevent from electric leakage accident.

### 運轉 Operation

1. 開關在一分鐘內反覆開與關，會引起馬達過熱，應加以避免。一部份的鼓風機：風口全開時會發生過負荷現象，此時使用電流表確認電流大小、緩衝器調整之，通常在定格電流內使用。
2. 變頻器控制：使用變頻器時電源歪曲，馬達聲音大，震動亦較大。如使用變頻器運轉，而溫度上升或震動大時，請停止運轉。一般請在下列條件下使用：
  - A. 最大週波數值(迴轉數) – 需為標示上所定週波數之內，並在定格電流之內。
  - B. 最小週波數(迴轉數) – 在30赫茲(Hz)以上，並於定格電流之內。
  - C. 單相馬達不能做變頻器運轉。
1. Part of blower  
Overload will be happened when it is completely opened.  
Avoid turn switch on and off repeatedly within one minute so as leading overheat of motor.
2. Control on frequency changer When frequency changer is used, power supply ripple is distorted, motor noise is loud, and vibration is big too. When using frequency changer for operation if leading to rise of temperature or vibration, please stop operation. Please use it under following terms and conditions.
  - (A) Maximum frequency (RPM) Must be kept within frequency as indicated and within rated amperage.
  - (B) Minimum frequency (RPM) Must be kept over 30 Hz, and within a rated amperage
  - (C) A single-phase motor can not be used to operate a frequency changer.

## 單位換算表 Measurement Conversion Table

### 壓力 Pressure

	mmAq	mbar	pa	kgf/cm <sup>2</sup>	atm	in Hg	lbf/in <sup>2</sup>
1mmAq	1	9.807x10 <sup>-2</sup>	9.807	10 <sup>-4</sup>	9.677x10 <sup>-5</sup>	2.896x10 <sup>-3</sup>	1.42x10 <sup>-2</sup>
1mbar	10.197	1	10 <sup>2</sup>	1.02x10 <sup>-3</sup>	9.869x10 <sup>-4</sup>	2.953x10 <sup>-2</sup>	1.45x10 <sup>-2</sup>
1pa	0.102	0.01	1	1.02x10 <sup>5</sup>	9.87x10 <sup>-6</sup>	2.953x10 <sup>-4</sup>	1.45x10 <sup>-4</sup>
1kgf/cm <sup>2</sup>	10 <sup>4</sup>	9.807x10 <sup>2</sup>	9.807x10 <sup>4</sup>	1	0.968	28.96	14.223
1atm	1.033x10 <sup>4</sup>	1.013x10 <sup>3</sup>	1.013x10 <sup>5</sup>	1.033	1	29.92	14.7
1in Hg	3.45x10 <sup>2</sup>	33.86	33.86x10 <sup>3</sup>	3.45x10 <sup>-2</sup>	3.342x10 <sup>-2</sup>	1	0.491
1lbf/in <sup>2</sup>	7.03x10 <sup>2</sup>	68.95	68.95x10 <sup>-2</sup>	7.03x10 <sup>-2</sup>	6.805x10 <sup>-2</sup>	2.036	1

### 風量 Air Flow

	m <sup>3</sup> /min	m <sup>3</sup> /hr	l/min	ft <sup>3</sup> /min(cfm)
1m <sup>3</sup> /min	1	60	1000	35.31
1m <sup>3</sup> /hr	0.017	1	16.67	0.589
1l/min	0.001	0.06	1	0.035
ft <sup>3</sup> /min(cfm)	0.028	1.699	28.32	1

### 功率 Power

	kW	HP	PS	kg-m/sec
1kW	1	1.341	1.360	101.97
1HP	0.746	1	1.014	76.038
1PS	0.736	0.986	1	75
1kg-m/sec	0.01	0.013	0.013	1

#### 常用壓力單位換算

Common Pressure  
Measurement Conversion

1Pa=0.102mmAq

1psi=703mmAq

1mbar = 10.197mmAq

1 bar = 1000 mbar

1mmHg=13.6mmAq

1kg/cm<sup>2</sup>=10000mmAq

1Torr=133.3Pa

1Torr=1.333mbar

F級絕緣馬達 · 高耐溫

鋁合金製造 · 機殼特厚

結構堅固 · 抗氧化 · 耐磨耐壓

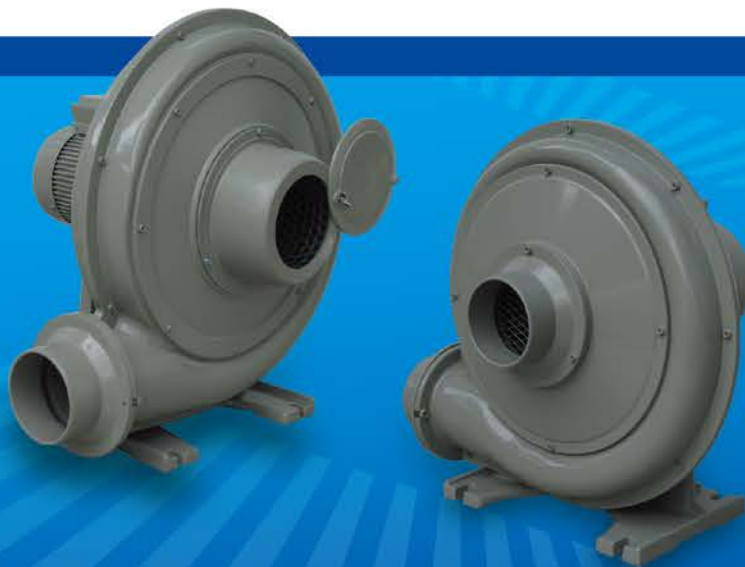

升圓企業有限公司

**SERVE-WELL ENTERPRISE CO., LTD.**

420台中市豐原區北陽路450巷154號

No 154, Lane 450, Pei Yang Rd.,  
Feng Yuan Dist, Taichung City, Taiwan 420

TEL:04-25228046

FAX:04-25248251

E-mail:serve.well@msa.hinet.net

<http://www.serve-well.com>